

3 x LED

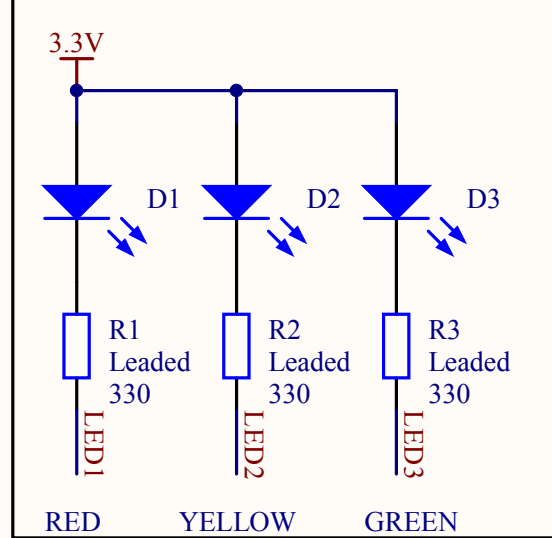

Potmeter

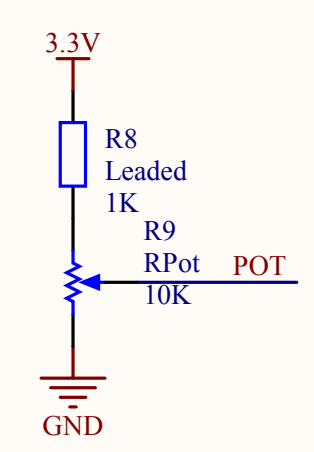

3 x 4 Keyboard

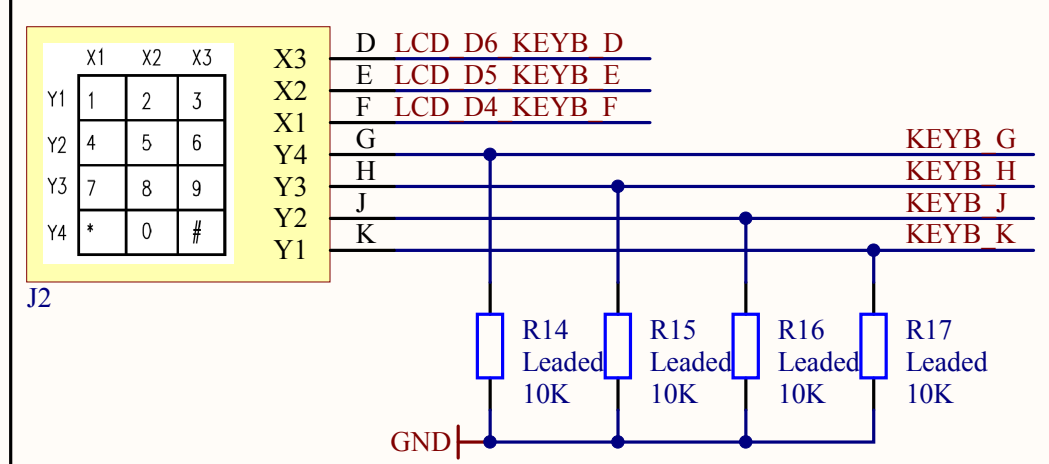

LCD display

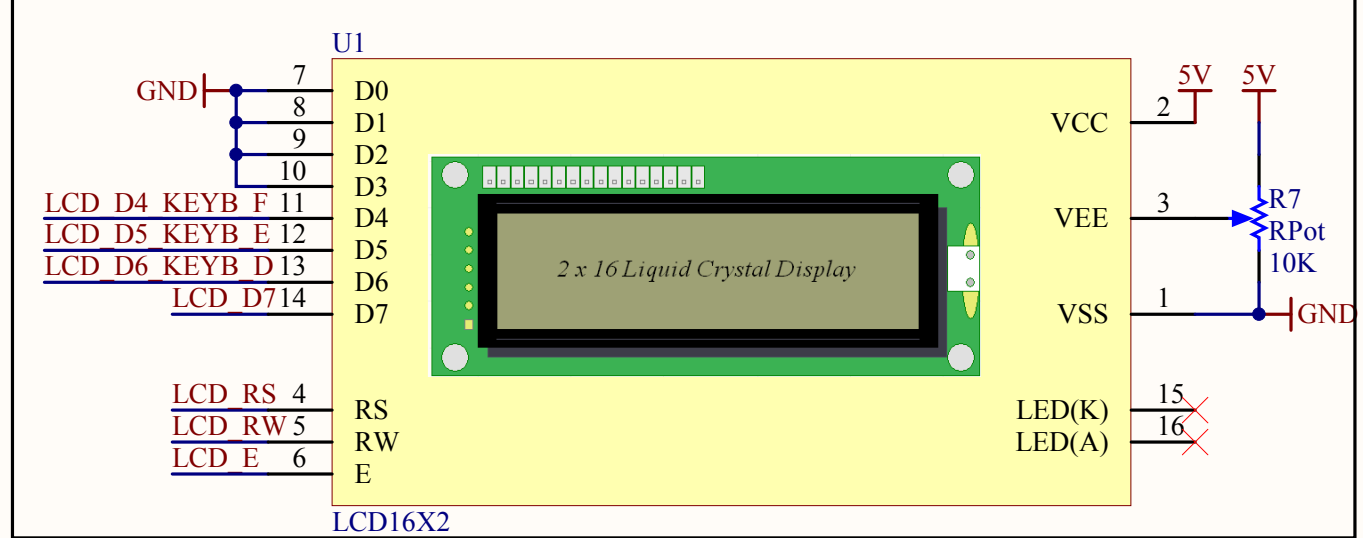

Digiswitch

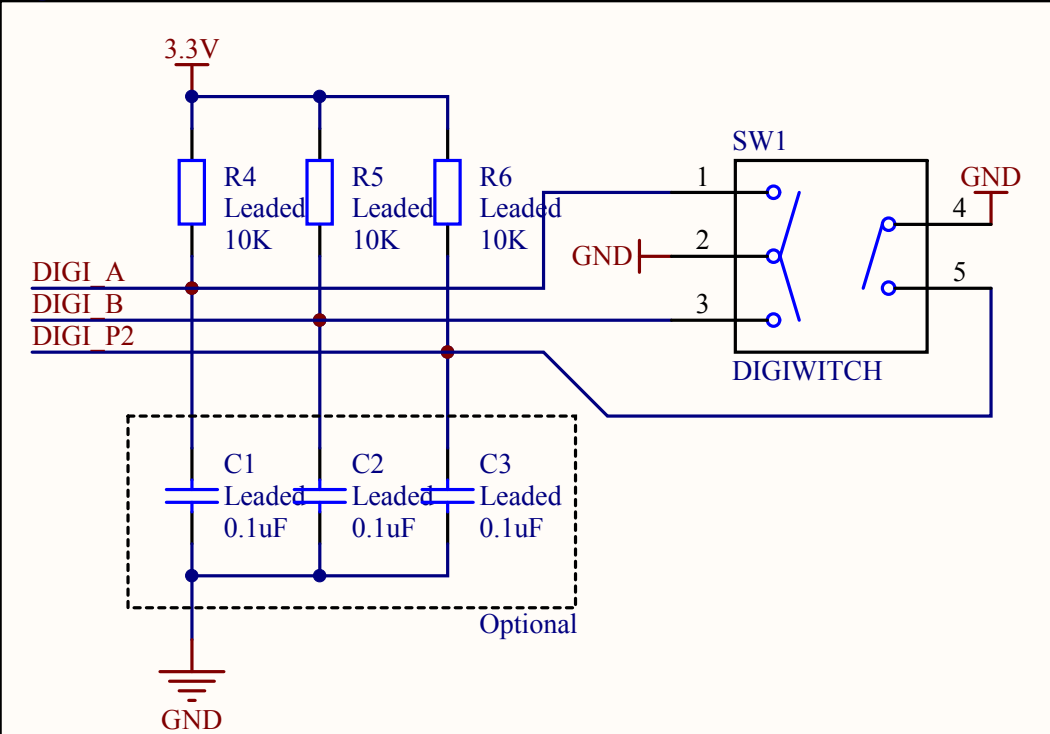

DC motor (Fan)

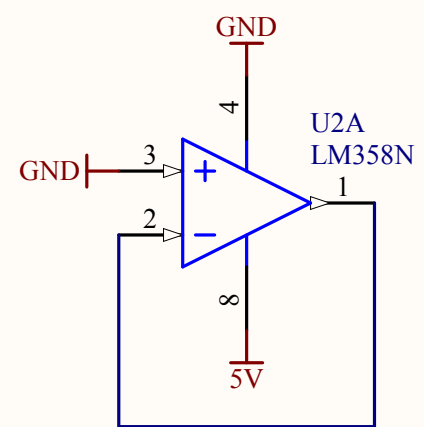
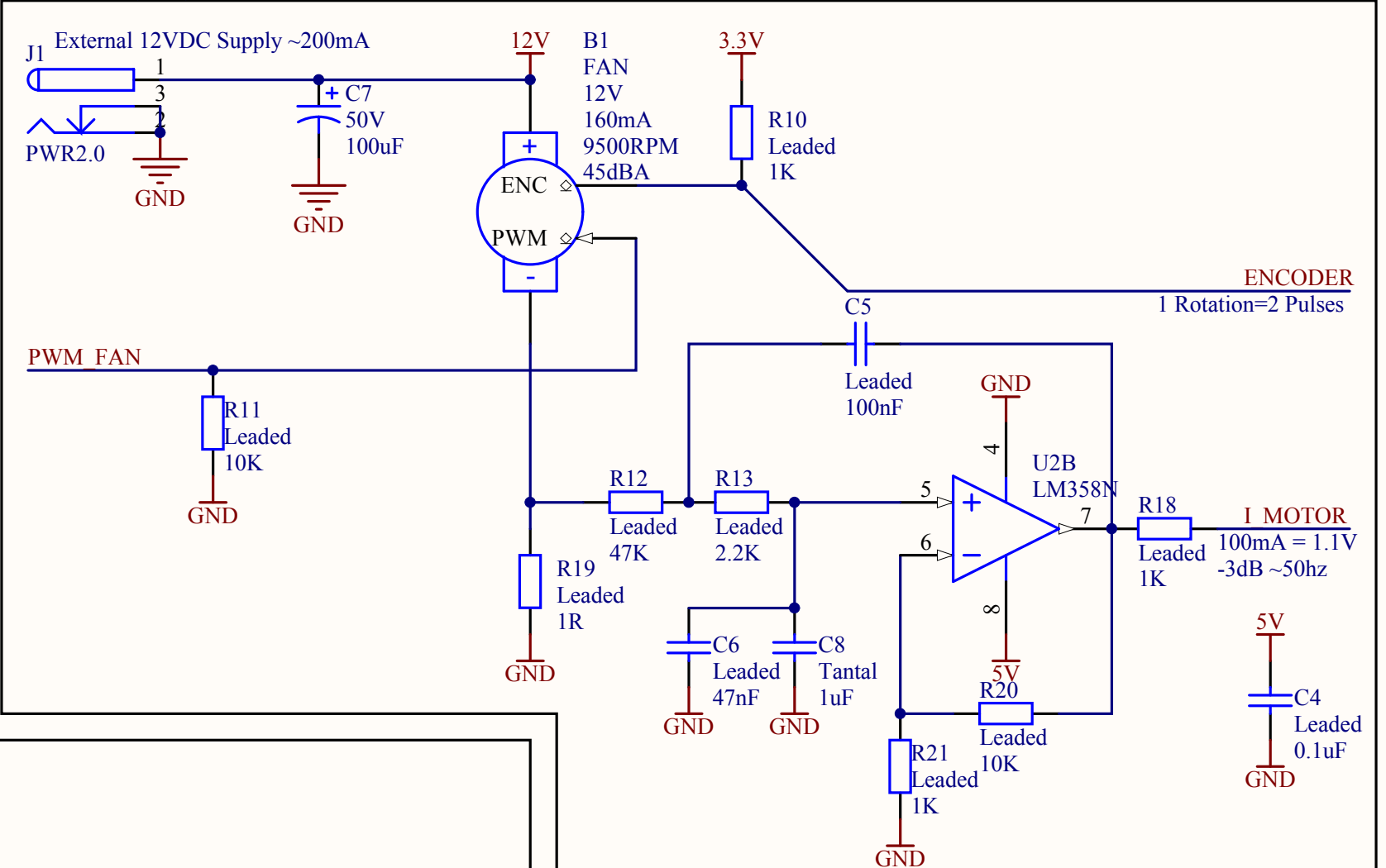

LM3S6965 Eval Board

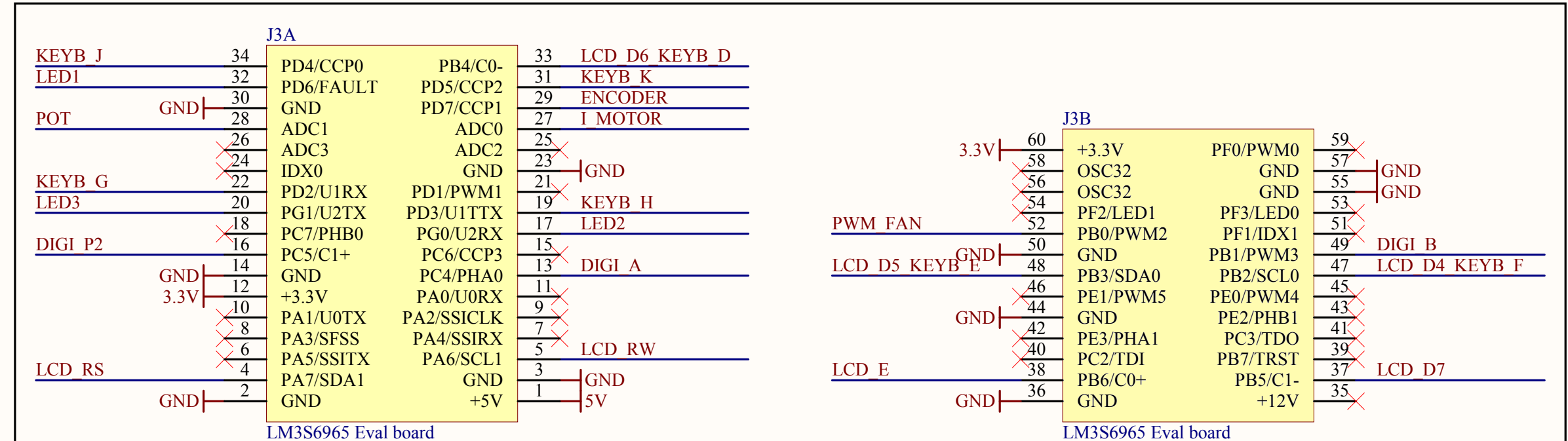

Title EMP_Board_V3.SchDoc		Mærsk Inst - SDU ROBOLAB J28B	
Project: EMP_ARM.PrjPcb		Revision:	
Date: 03-01-2011		Modified: 03-01-2011	
Drawn by: Caalb		Niels Bohrs Allé 1 5230 Odense M Denmark	

J3

LM3S6965 Eval Board

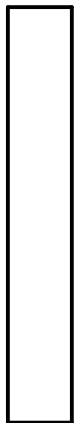
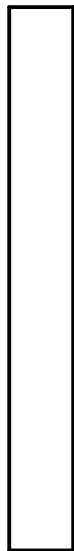

MMMI 08-2009
PCB: Caalb

Rev: 0.3

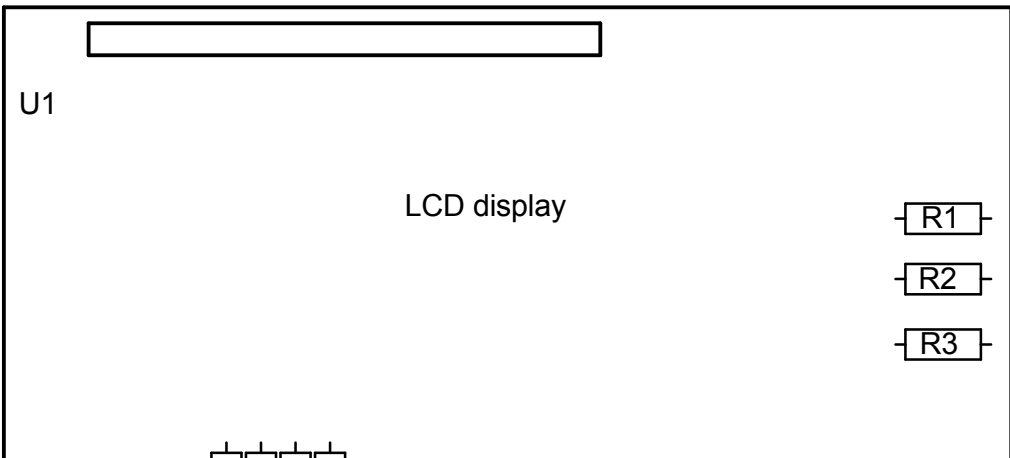

J2

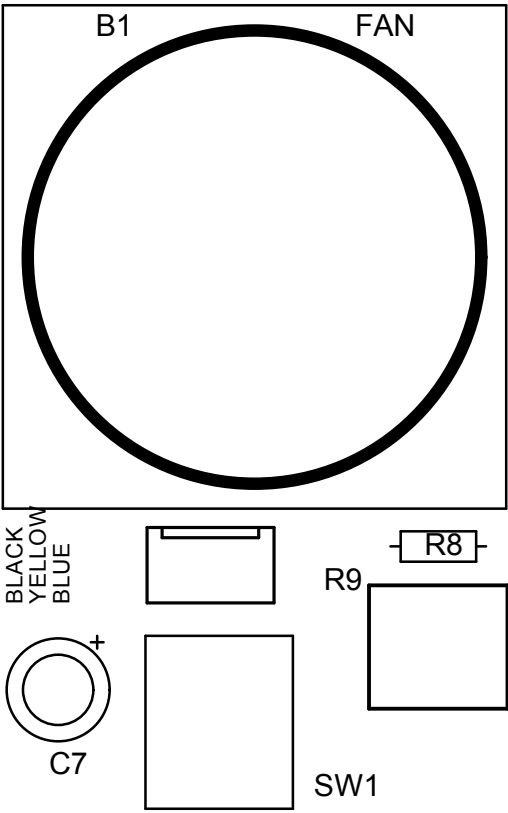
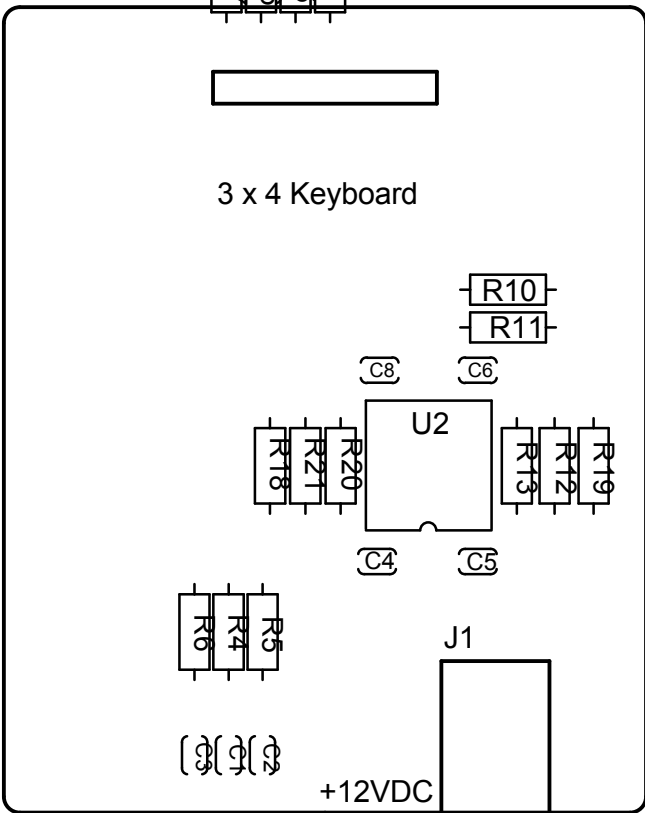

R7

CONTRAST

RED

YELLOW

GREEN

RED

BLACK

YELLOW

BLUE

+12VDC

SW1

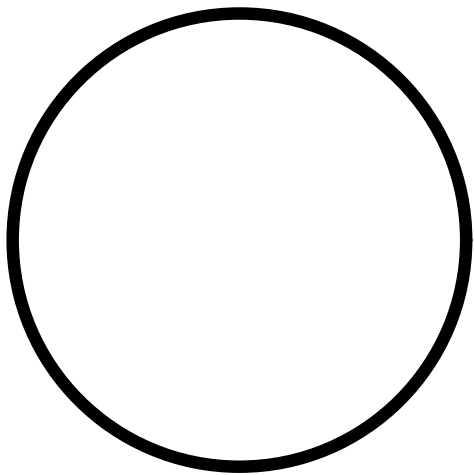

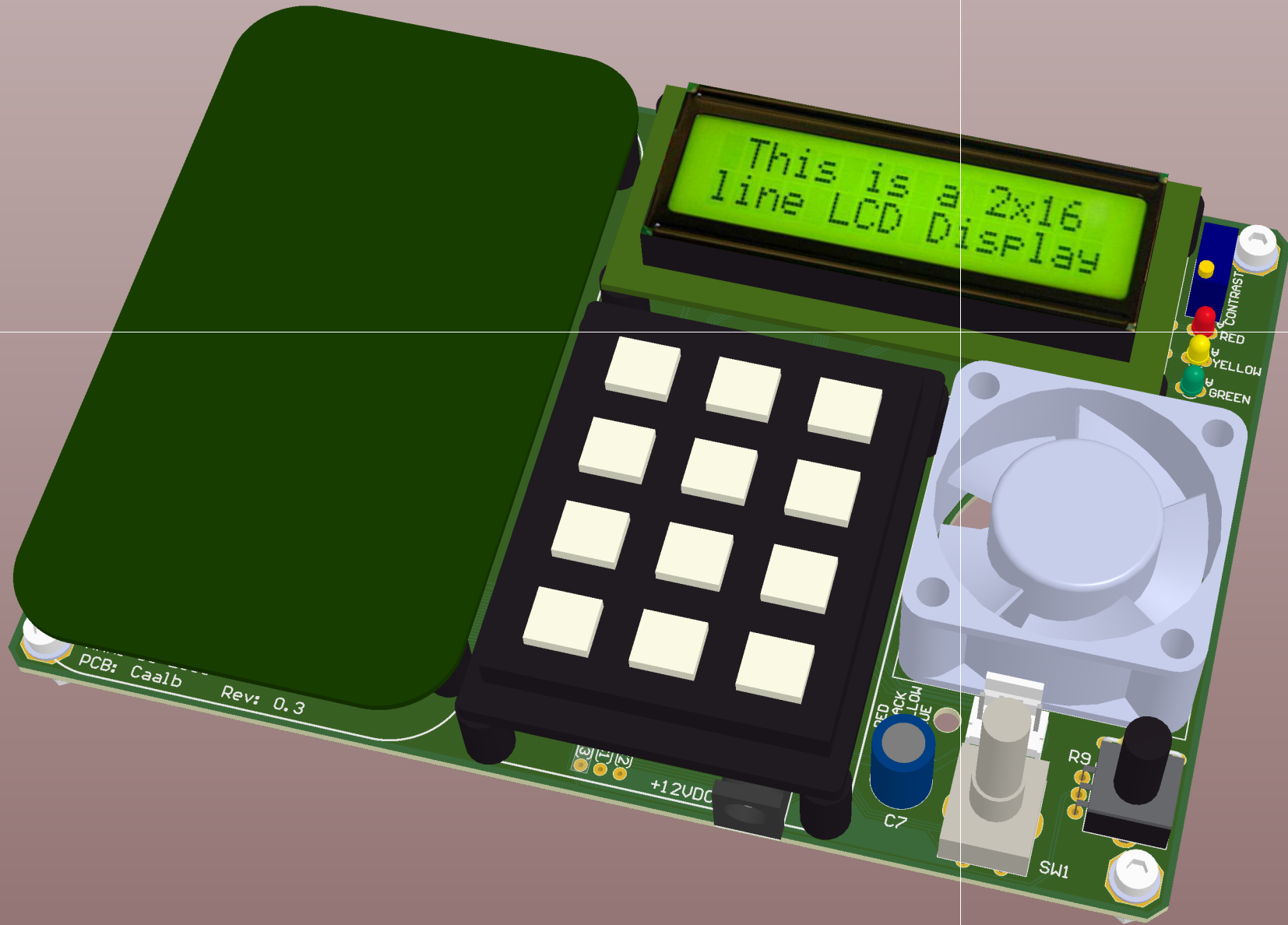

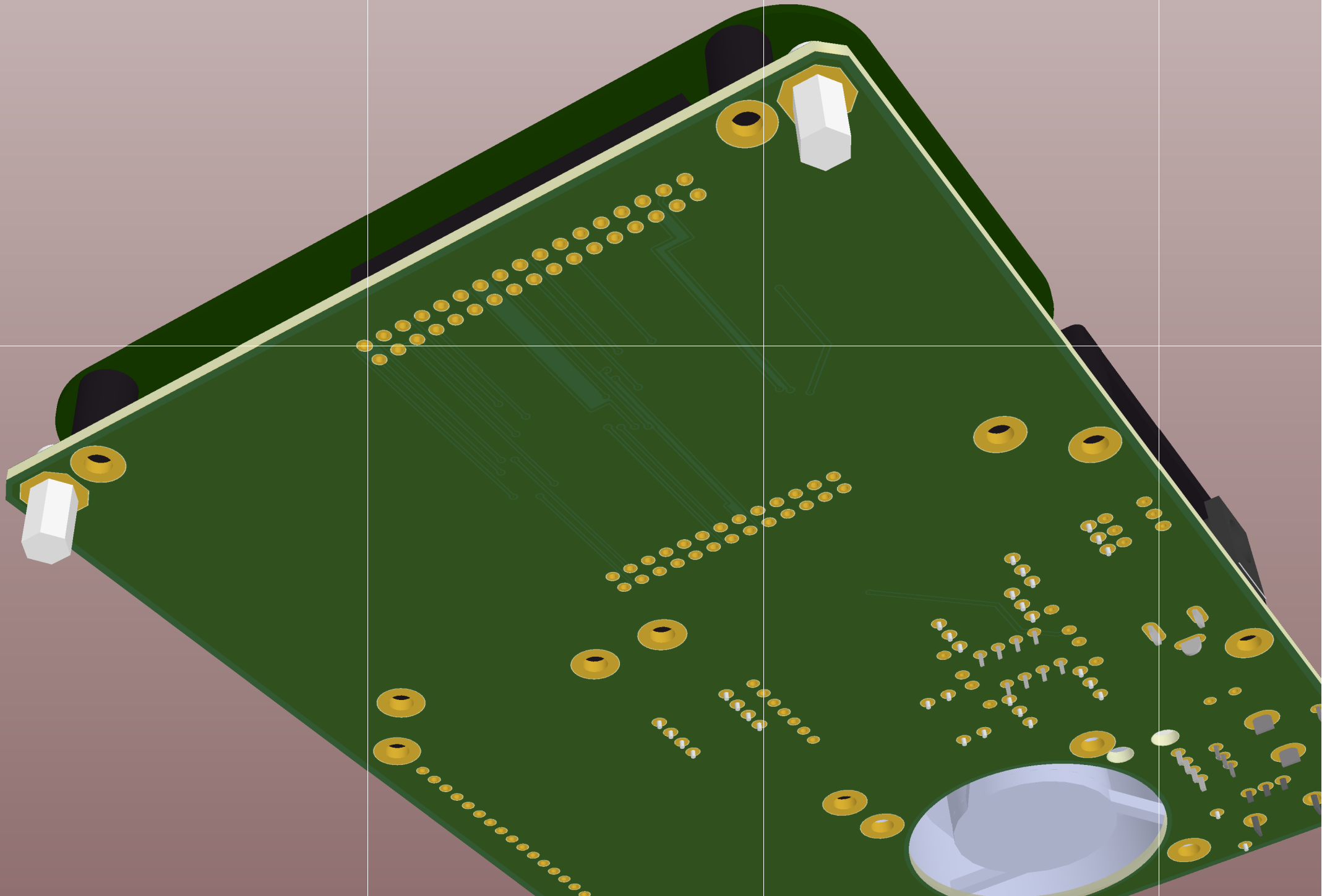

Bill of Materials



Project: EMP_ARM.PrjPcb
 Variant: None
 Creation Date: 03-01-2011 10:07:14
 Print Date: 03-01-2011 03-01-2011 10:07
 Drawn By: Caalb

Address: Mærsk Inst - SDU
ROBOLAB J28B
Niels Bohrs Allé 1
5230 Odense M
Denmark

Value	Comment	Description	Designator	Footprint	PN Digikey	#Column Name	#Column Name	#Column Name	Quantity
330	Leaded	Resistor	R1, R2, R3	RESA10					3
100uF	50V	Polarized Capacitor (Radial)	C7	CAP 100uF 50V					1
100nF	Leaded	Capacitor	C5	Cap 5.08					1
47nF	Leaded	Capacitor	C6	Cap 5.08					1
47K	Leaded	Resistor	R12	RESA10					1
10K	Leaded	Resistor	R4, R5, R6, R11, R14, R15, R16, R17, R20	RESA10					9
10K	RPot	Potentiometer	R7, R9	ALPS 9MM SNAP-IN, POT 3296					2
2.2K	Leaded	Resistor	R13	RESA10					1
1uF	Tantal	Capacitor	C8	Cap 5.08					1
1R	Leaded	Resistor	R19	RESA10					1
1K	Leaded	Resistor	R8, R10, R18, R21	RESA10					4
0.1uF	Leaded	Capacitor	C1, C2, C3, C4	Cap 5.08					4
	3x4_Keyboard	3x4_Keyboard	J2	3x4Matrix keypad					1
	DIGIWITCH		SW1	STEC11B03					1
	FAN	FAN 40x40x20 Papst	B1	40x40x20 FAN	603-1206-ND				1
	Green	LED 3mm Green	D3	LED3G					1
	LCD16X2	LCD16X2	U1	Display 2x16					1
	LM358N	Low Power Dual Operational Amplifier	U2	Dip8					1
	LM3S6965 Eval board	LM3S6965 Eval board	J3	LM3S6965 Eval Board					1
	M3	Hole + M3 Hex Spacer	H1, H2, H3, H4	Hole + M3 Hex Spacer					4
	PWR2.0	Low Voltage Power Supply Connector	J1	DC FATN Ø2.0					1
	RED	LED 3mm Red	D1	LED3R					1
	Yellow	LED 3mm Yellow	D2	LED3Y					1
								Total:	43